

Hardt's 'Cleaning Solution' utilizes a gentle patented detergent to crystalize and dissolve burnt-on grease and carbon from cooking accessories such as skewers, pans, baskets, racks as well as ventilation hood filters.



Hardt Detergent

This patented powder is non-caustic, non-toxic and biodegradable. When mixed with water it produces a non-corrosive cleaning agent which allows for cleaning of most metals.

30-day Operating Cycle

The unit is drained, rinsed and refilled only once every 30 days. The solution is then easily drained with no spillage. This saves on water and detergent.

One-Touch Open/Close

The power-operated lid and basket open and close with the touch of a button.

Basket-Within-Tank Design

Allows for items to be lifted above the water line for easy and safe loading and unloading. The basket rises and descends automatically with the lid.

Powerful Soaking Action

Removes burnt-on grease and carbon, and penetrates deep into corners and crevices with no scrubbing. Simply load and let the system do the work. The holding tank water is kept above 165° F and allows for overnight soaking.

Easy to use

The cleaning process is simple. Load accessories, let them soak, remove and rinse.

Labor-Saver & Morale Booster

Less time spent scrubbing means more time for other tasks. It also eliminates a labor intensive job which will increase morale. The unit's ease of use makes it a snap to train on.

Food Safety

Food safety is enhanced by thoroughly cleaning the items that come in contact with the food that is cooked.

Employee Safety

Workers can use the equipment knowing they will avoid contact with hazardous chemicals.

Also Available

Electric Boilerless Ovens



Rotisserie Ovens



Island Hot Cases



Bread Roll Merchandiser



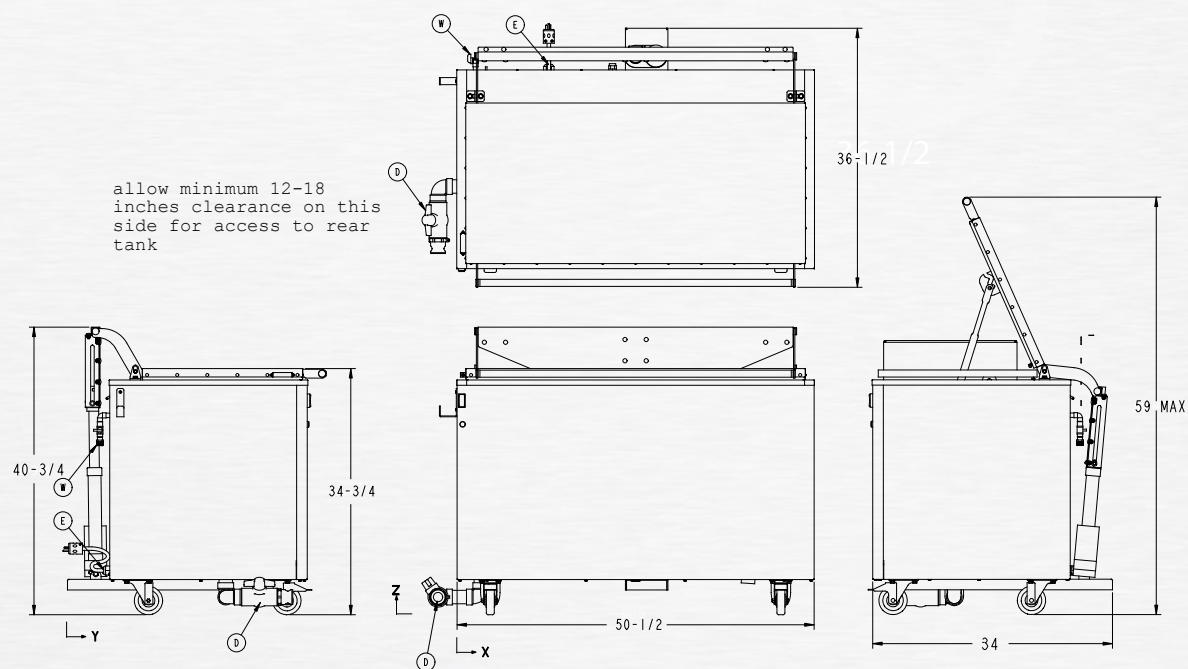

ref 99-10062-3

Installation

Connections	X Position	Y Position	Z Position	Description
Electrical (E)	13	5	6	120 VAC, 20A, 60Hz, SINGLE PHASE 8 FT POWER CORD WITH NEMA 5-20 PLUG INCLUDED
Water Inlet (W) Optional	2 ³ / ₄	4 ¹ / ₂	24	STANDARD 1" WASHING MACHINE HOSE CONNECTION
Drain (D)	-2 ³ / ₄	31 ³ / ₄	2 ¹ / ₂	ø1 ¹ / ₂ ID x 8 FT LONG REMOVABLE HOSE INCLUDED

Notes

- Water capacity is 67 gallons (255 L)
- Shipping weight is 610 lbs (277 Kg)
- Basket Internal Dimensions are: 44 1/4" L x 17 1/2" W x 10 3/4" H
- Basket capacity is not to exceed 125 lbs (57Kg)
- A floor drain should be located within 8 ft from the left side of the tank (position D)
- Easily accommodate a wide range of cooking utensils (such as rotisserie skewers and baskets) in its long, low basket.
- If optional water inlet is purchased (P/N -20506):
 - A plumber should install a standard washing machine spigot on the wall close to the rear-left corner of the tank. This allows for a standard 1"x 6 ft long hose to be connected between the spigot and the tank
 - A 4 ft quick disconnect water hose (P/N 5124) may also be purchased that uses 1/2" -NPT threaded connections
 - The water supply may be cold or hot, the colder the water, the longer will be the initial heat up. Hot water is preferred