

The Combi-Q is designed to excel under rigorous conditions for fast-paced and high-volume requirements. The Combi-Q gives you the control required to perform a variety of cooking applications to perfection each time. Baking, roasting, grilling, steaming and many more cooking modes are all available and combinable in a single unit.



Water & Energy-Efficient

The Combi-Q10's use of water and electricity is optimized for high-volume cooking. The dual-pane door with infrared reflective coating and the double insulated cooking chamber reduce heat loss for enhanced energy efficiency.

Safety Features

The AutoClean feature ensures that employees do not come into contact with chemicals while the drip tray under the door keeps the floor dry, avoiding a slippery floor in front of the machine. The dual-pane door design keeps the outer glass cool. Upon opening the door a valve opens to release steam.

User-Friendly

Easy-to-use controls, displayed in English, French, or Spanish, can be pre-programmed for one-touch cooking. On-screen messages, multi-batch cooking timer, and temperature probe make the most complex cooking programs simple to follow. Each Combi-Q can store up to 200, 6-step cooking programs so you can build a repertoire of tantalizing options.

Automatic Cleaning

The powerful AutoClean system cleans with just a push of the button after inserting the single-dose detergent pouch inside the cooking chamber. A spray hose further simplifies the cleaning process.

Wireless Programming

The innovative RFID technology allows cooking programs to be transferred from one store to another simply by holding the RFID tag against the Combi-Q's control panel. Each tag can store up to 20 programs. Also included are USB capabilities for uploading, downloading, service upgrades and storage of up to 200 programs. This ensures cooking consistency across all store locations, without requiring experienced staff.

Easy Maintenance

The Combi-Q is intelligently designed and is constructed using fewer parts than comparable ovens, making maintenance less costly. Service access through the front of the control panel and on-screen diagnostics aid the technician, saving you time and money.

Versatile Design

The door can be hinged from the left or right to adapt to different kitchen layouts.



ENERGYWISE



AUTOCLEAN



DOUBLE-DECK
OPTION



RFID

Options

Double Deck Configuration

Wireless RFID Programming

USB Key Stores 200 Programs

Recipe Booklet Available



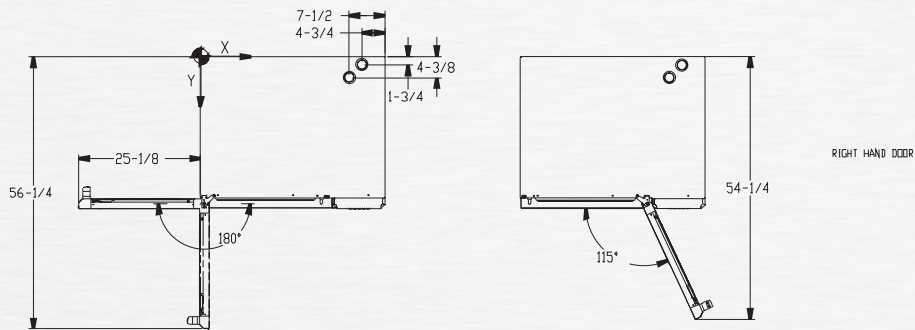
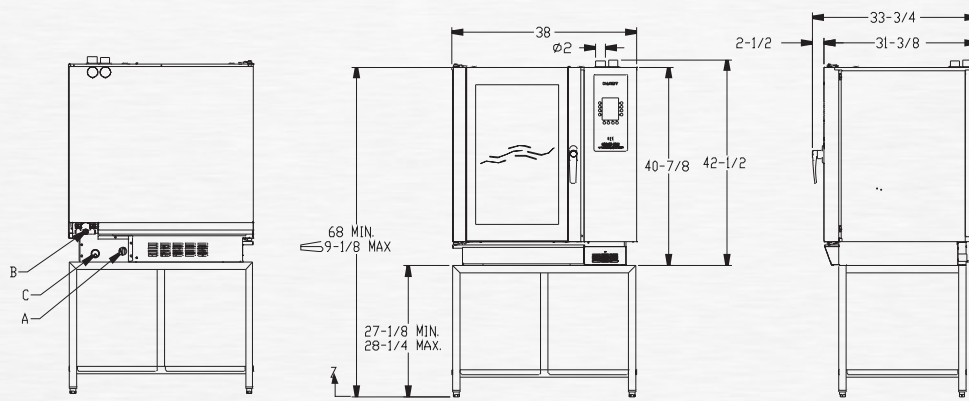

ref 30637-1

Installation

Connections	Item	X Position	Y Position	Z Position	Terminations
Power Cable	A	27	2 1/8	28 3/8	UL: PLUG NEMA 15-60P CSA: PLUG LEVITON 100 AMP, 4100P9W
Water Inlet	B	34 5/8	1 1/2	33 1/4	3/4 -12 GARDEN HOSE THREAD
Drain	C	32 5/8	1 7/8	28 3/4	40mm (1.575")

X, Y and Z dimensions are given in inches. Height from floor (Z) assumes use of optional stand #30204.

Specifications and Options

Power consumption	18.5kW
Weight	375 lbs
Electrical requirements	208V, 3 phase, 60Hz
Pan capacity	10 pans of 18" x 26" (with 2.9" spacing)
Warranty	2 Years Parts & Labor
Shell construction	All stainless steel
Included accessories	<ul style="list-style-type: none"> Basic plumbing hardware Owner's manual Spray hose
Options	<ul style="list-style-type: none"> Double-deck configuration
Available accessories	<ul style="list-style-type: none"> Oven stand USB key RFID tag

Notes

- Hood may be required by local ordinance
- Water pressure: 30-75 psi (2-5 bar)
- Water feed to be cold (maximum 70 PPM hardness rating)

Also Available

